



## ***Multi-Purpose Portable Balances for the Classroom***

NVE series portable balances are designed for demanding classroom applications with features such as superior overload protection and a stackable design. Durably constructed and multifunctional, the NVE is a powerful balance that can handle a diverse range of weighing applications in the classroom such as parts counting, percent weighing, and checkweighing.

### ***Standard Features:***

- The practical space-saving design allows for stackable storage together with the AC adapters.
- Integrated overload protection system that can withstand loads up to four times the rated capacity protects the balance in demanding classroom environments.
- Advanced software allows you to secure and lock the menu settings and calibration operation, making it easier for teachers to manage the balances during school experiments.

# NVE SERIES *Portable Balances*

Model	NVE612	NVE2102
Capacity (g)	610	2100
Readability (g)	0.01	0.01
Repeatability (Std. Dev.) (g)	0.02	0.02
Linearity (g)	0.02	0.03
Span Calibration Mass (Not Included)	300 g	1000 g
Linearity Calibration Mass	300, 600 g	1000 g, 2000 g
Stabilization Time (s)	1.5	
Construction	ABS housing & stainless steel pan	
Calibration	Digital with external weight	
Tare Range	Full capacity by subtraction	
Weighing Units	g, lb, oz, N	g, kg, lb, oz, N
Application Modes	Weighing, Parts Counting, Percent Weighing, Checkweighing	
Power Requirement	AC adapter (included) or Four C batteries (not included)	
Typical Battery Life	270 hours with alkaline batteries	
Specified Temperature Range	10° C to 40° C at 10% to 85% relative humidity, non-condensing	
Storage Conditions	-20° C to 55° C at 10% to 90% relative humidity, non-condensing	
Communication	RS232, USB, or Ethernet (available as accessories)	
Display Type	Liquid Crystal Display (LCD) with backlight	
Display Size	20 mm digits	
Pan Size (W x D)	Ø 145 mm	190 x 144 mm
Balance Dimensions (W x D x H)	204 x 230 x 70 mm	
Shipping Dimensions (W x D x H)	300 x 250 x 182 mm	
Net Weight	1.0 kg / 2.2 lb	
Shipping Weight	1.5 kg / 3.3 lb	

## Other Standard Features and Equipment

ABS housing, stainless steel pan, transportation lock, storage & stacking cover (included), menu and calibration lock switch, slip-resistant and adjustable feet, leveling bubble, mechanical and software overload/underload protection, stability indicator, low battery indicator, auto shut-off, user-selectable print options, user-selectable communication settings

## Compliance

- **Product Safety:** IEC/EN 61010-1; CAN/CSA C22.2 No. 61010-1; UL Std. No. 61010-1
- **Electromagnetic Compatibility:** IEC/EN 61326-1 Class B; FCC Part 15 Class B; Industry Canada ICES-003 Class B
- **Other:** WEEE/RoHS

## Accessories

USB Interface .....	83032108	Adapter with plugs (EU-US-UK-AU-KR) .....	30467987
RS232 Interface .....	83032107	Stacking Kit, x1 .....	30467917
Ethernet Interface .....	83032109	Stacking Kit, x6 .....	30467918
Rechargeable Battery Kit .....	83032106	Printer, SF40A .....	30045641
Carrying Case .....	30467963		

## Outline Dimensions

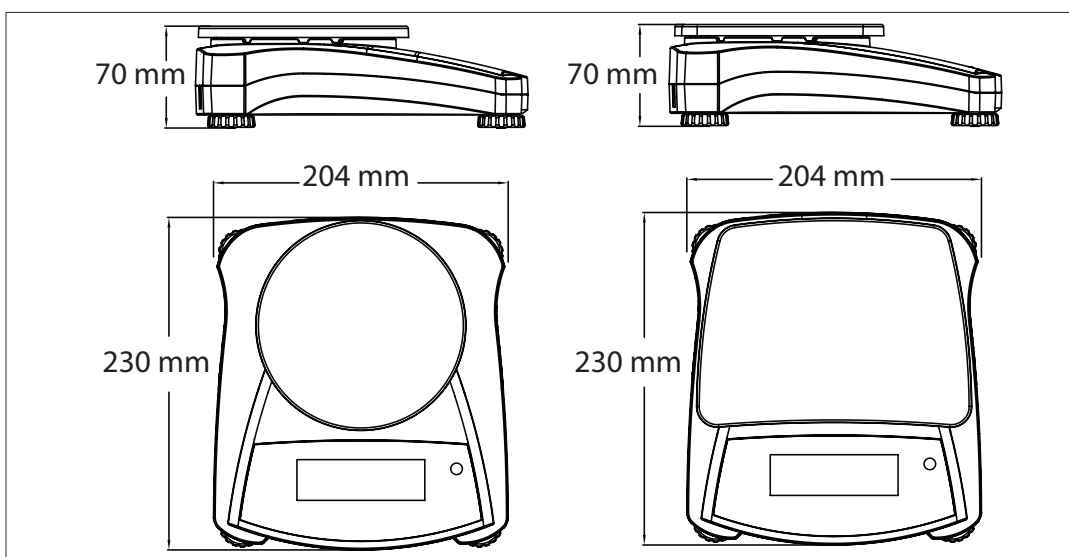

### OHAUS Asia/Pacific Headquarters

7F, Block 33, 680 Guiping Road  
Shanghai 200233  
China

e-mail: APmarketing@ohaus.com  
Tel: +86 21 64855408

[www.ohaus.com](http://www.ohaus.com)

*The management system governing the manufacture of this product is ISO 9001:2015 certified.*

SAP Literature #

